

第48回日本神経科学大会

The 48th Annual Meeting of the Japan Neuroscience Society

2025年7月24日(木)～7月27日(日) July 24-27, 2025

心に描く
神経科学の未来予想図
Future projection of neuroscience as envisioned in the mind

会場
Venue

朱鷺メッセ(新潟市)
Toki MESSE, Niigata, JAPAN

大会長
President

藤山 文乃(北海道大学大学院医学研究院)
Fumino Fujiyama
(Faculty of Medicine and Graduate School of Medicine, Hokkaido University)

Plenary Lectures



Chris I. De Zeeuw
Netherlands Institute
for Neuroscience, Netherlands



Sheena A. Josselyn
Hospital for Sick Children, Canada



Maiken Nedergaard
University of Rochester, USA/
University of Copenhagen, Denmark



Franck Polleux
Columbia University, USA

<https://neuroscience2025.jnss.org/>



Sponsorship Prospectus

Greetings

The 48th Annual Meeting of the Japan Neuroscience Society will be held from Thursday, July 24th, to Sunday, July 27th, 2025, at the Toki Messe Niigata Convention Center in Niigata. In addition to celebrating the 50th anniversary of the establishment of the Japan Neuroscience Society, which initially comprised only 70 members, we are actively preparing for a fulfilling and exciting conference, including the invitations of world-class neuroscientists and the organization of various events to celebrate this milestone. We invite you to join us, looking forward to welcoming your presence at this momentous occasion.

Over the past five decades, the landscape of neuroscience has undergone a profound transformation. A multitude of disciplines are actively engaged in unraveling the grand mysteries of the brain, including molecular biology, cell biology, biophysics, anatomy, physiology, biochemistry, pharmacology, psychology, behavioral science, information science, technology, mathematics, and clinical medicine. Furthermore, cutting-edge technological innovations from various fields, including academia and industry, have accelerated the progress of neuroscience. With this remarkable advancement, the Japan Neuroscience Society, founded half a century ago, has emerged as the largest academic organization in neuroscience in Japan, boasting over 6,000 researchers across a wide spectrum of disciplines.

Since the inaugural academic gathering of the Society in 1978, our annual meetings have consistently served as a central forum for the presentation of research findings and the exchange of information, fostering the advancement of the field as a whole. Throughout this period, even in challenging circumstances such as natural disasters and pandemics, the pivotal role of the annual conference has persevered, thanks to the unwavering dedication of all participants and members involved.

The theme of this year's Annual Meeting is "A future projection of neuroscience as envisioned in the mind."

Amidst the dynamic trends enveloping neuroscience, influenced by societal conditions and technological advancements, what aspirations will neuroscientists hold for the next five decades? Each researcher envisions a distinct future in his/her mind, encompassing pursuits such as unraveling the operational principles of the brain, comprehending the intricacies of the mind, interpreting societal dynamics through a neuroscientific lens, and exploring and treating neurological and psychiatric disorders. By uniting these diverse visions and fostering interdisciplinary interactions that transcend boundaries of specializations, genders, ages, and nationalities, our future projections can become both more realistic and more hopeful. Furthermore, to establish a meaningful link between this field and the unfolding years, it is imperative to develop the next generation. In addition to enhancing educational programs designed to facilitate a shared language for understanding the increasingly specialized and advanced subfields of neuroscience, our aim is to create an inclusive learning environment that engages young researchers, graduate students, university scholars, and even the emerging generations beyond.

We sincerely hope that this year's meeting will mark the first step: the start of the next 50 years of this society, and the beginning of the road to our 100th anniversary.

Fumino Fujiyama
President of the 48th Annual Meeting of the Japan Neuroscience Society
(Faculty of Medicine and Graduate School of Medicine, Hokkaido University)



The 48th Annual Meeting of the Japan Neuroscience Society

General Information



General Information

Name

The 48th Annual Meeting of the Japan Neuroscience Society

President

Fumino Fujiyama
(Faculty of Medicine and Graduate School of Medicine, Hokkaido University)

Theme

Future projection of neuroscience as envisioned in the mind

Dates

July 24-27, 2025

Venue

TOKI MESSE
6-1 Bandaijima, Chuo-ku, Niigata City, Niigata 950-0078 Japan
<https://www.tokimesse.com/english/>

Expected number of participants

3,000 (Incl. invitees)

Society secretariat

The Japan Neuroscience Society
9F, Hongo Bldg., 7-2-2 Hongo, Bunkyo-ku, Tokyo 113-0033 Japan
Phone: +81-3-3813-0295

Contact

Neuroscience 2025 Sponsorship Secretariat (c/o A&E Planning Co.,Ltd.)
4F, Hitotsubashi Bekkan, 2-4-4, Hitotsubashi, Chiyoda-ku, Tokyo 101-0003 Japan
Phone: +81-3-3230-2744 Email: e_jns2025@aeplan.co.jp



Organizers

President

Fumino Fujiyama Hokkaido University

Executive Committee

Chair Takayasu Mikuni Niigata University

Members Ritsuko Hanajima Tottori University

Yu Hayashi University of Tokyo

Sakiko Honjoh University of Tsukuba

Hirokazu Iwamuro Juntendo University

Susumu Jitsuki Mie University

Kazuo Kitamura University of Yamanashi

Fumi Kubo RIKEN

Hideaki Matsui Niigata University

Masanori Murayama RIKEN

Hiroyuki Nawa Wakayama Medical University

Hiroyuki Okuno Kagoshima University

Hirohide Takebayashi Niigata University

Masaki Tanaka Hokkaido University

Miho Terunuma Niigata University

Masaki Ueno Niigata University

Yoshikazu Ugawa Fukushima Medical University

Masahiko Watanabe Hokkaido University

Keisuke Yonehara National Institute of Genetics



Organizers

Program Committee

Chair	Takuya Sasaki	Tohoku University
Core Members	Kaoru Amano	The University of Tokyo
	Nariko Arimura	Tohoku University
	Hiroyuki Hioki	Juntendo University
	Naoki Matsuo	Kyushu University
	Hiroshi Nomura	Nagoya City University
	Mayu Takahashi	Tokyo Medical and Dental University
	Keiko Takanami	Nara Women's University
	Tomohiko Takei	Tamagawa University
	Takayuki Yamashita	Fujita Health University

Organization Committee

Members	Kenji Doya	Okinawa Institute of Science and Technology Graduate University
	Noriko Osumi	Tohoku University
	Ryosuke Takahashi	Kyoto University
	Shigeo Okabe	The University of Tokyo
	Tadashi Isa	Kyoto University
	Takashi Hanakawa	Kyoto University
	Yukiko Gotoh	University of Tokyo



Budget (as of April, 2024)

Income			
Item		Amount (JPY)	Remarks
1.	Registration fee	37,245,000	2,400 participants
2.	Seminar	13,150,000	8 seminars
3.	Sponsorship package	19,790,000	8 companies
4.	Exhibition	26,664,000	95 booths
5.	Advertising	2,726,000	Program booklet ad, Web banner etc.
6.	Donation	19,964,000	Incl. grants from various foundations, etc.
7.	Loan from the society	1,500,000	
Total		121,039,000	

Expenditure			
Item		Amount (JPY)	Remarks
1.	Preparation	<u>30,612,000</u>	
	1) Personnel	13,323,000	
	2) System-related	9,233,000	Incl. website, abstract submission/registration systems
	3) Print/Production	4,438,120	Incl. translation
	4) Communication/Transportation	3,617,880	
2.	On-site operation	<u>86,070,000</u>	
	1) Venue	20,000,000	
	2) Equipment	30,373,500	
	3) Personnel	12,476,000	
	4) Invitation	10,000,000	
	5) Meeting	7,531,300	
	6) Miscellaneous	2,589,200	
	7) Open lecture	3,100,000	
3.	Post-meeting operation	<u>3,226,000</u>	
4.	Reserve fund	<u>1,131,000</u>	
Total		121,039,000	



Invoice Number & Cancellation Policy

■ Qualified invoice issuer registration number (Invoice number)

This meeting is not yet registered as a qualified invoice issuer, but we plan to register in the future. We will inform you once the number has been acquired.

■ Cancellation policy

Please ensure that you agree to the following policy before submitting your application.

Cancellation of application

Once an application has been received, it cannot be canceled unless the organizing committee deems the reason to be beyond the applicant's control. Even if the organizing committee accepts the cancellation, please provide a written notice of the reason for cancellation and pay the cancellation fee based on the date the notice is received.

[Cancellation fee]

When a cancellation notice is received ...

by the application deadline : 50% of the amount billed

on and after the application deadline : Full amount billed

Change or Cancellation of the annual meeting

In the event of natural disasters, other unavoidable circumstances, or causes beyond the control of the organizer, the annual meeting and exhibition may be changed or canceled.

No compensation for damages or losses caused by such changes will be paid by the organizer to the sponsoring companies. If the annual meeting or exhibition is canceled for the reasons mentioned above, the organizer will deduct preparation costs from the sponsorship fee and refund the remaining amount to the sponsoring companies, depending on the timing of the cancellation decision.



The 48th Annual Meeting of the Japan Neuroscience Society

Sponsorship Opportunities



List of Sponsorship Opportunities

Please refer to the respective pages for details. * All prices include tax.

■ **Sponsorship package** : JPY2,200,000~JPY3,300,000

Special packages include luncheon seminar, exhibition, web banner etc.

■ **Luncheon seminar** : JPY1,760,000

Seminars can be held in lecture rooms during lunchtime.

■ **Program booklet advertising** : JPY99,000~JPY297,000

Advertising in the program booklets (B5) is available.

■ **Web banner advertising on the meeting website** : JPY242,000

Web banners can be placed on the meeting website and will be displayed on multiple pages.

■ **Screen advertising** : JPY187,000

Promotional slides and videos can be projected on the screens in the lecture rooms and the rest areas during break times.

■ **Congress bag sponsor** : JPY385,000

Your company's logo can be printed on the congress bags that will be distributed to participants.

■ **Flyer insertion in congress bags** : JPY132,000

Flyers can be inserted into the congress bags that will be distributed to participants.

■ **Neck strap sponsor** : JPY1,870,000

Your company's logo can be printed on the neck straps that will be worn by participants.

■ **Exhibition** : Type A - JPY297,000 / Type B - JPY33,000 / Type C - JPY132,000

The exhibition will be held at the same venue as the poster presentation.

For Type B, a booth will be assigned in a smaller venue depending on the details of your application.



The 48th Annual Meeting of the Japan Neuroscience Society

Sponsorship Package



Sponsorship Package (1)

Platinum / Gold / Silver sponsorship packages are available.

Application deadline for sponsorship package: March 14, 2025

* Please finalize the theme, chairperson, and speaker for the luncheon seminar before applying. Applications will not be accepted if these details have not been confirmed.

Platinum

JPY3,300,000 (Incl.tax)

● The package includes

Normal price (JPY, Incl.tax)

1	Luncheon seminar	×1	First priority in selecting the date & room	1,760,000
2	Exhibition booth (A)	×5	First priority in selecting the booth location	1,485,000
3	Web banner	×1		242,000
4	Meeting pass	×5	Incl. admission to the banquet	160,000
5	Video streaming & Product introduction	×1		385,000
Total normal price				4,032,000

Gold

JPY2,530,000 (Incl.tax)

● The package includes

Normal price (JPY, Incl.tax)

1	Luncheon seminar	×1	Second priority in selecting the date & room	1,760,000
2	Exhibition booth (A)	×2	Second priority in selecting the booth location	594,000
3	Web banner	×1		242,000
4	Meeting pass	×3	Incl. admission to the banquet	96,000
5	Video streaming & Product introduction	×1		385,000
Total normal price				3,077,000

Silver

JPY2,200,000 (Incl.tax)

● The package includes

Normal price (JPY, Incl.tax)

1	Luncheon seminar	×1	Priority in selecting the date & room	1,760,000
2	Exhibition booth (A)	×1	Priority in selecting the booth location	297,000
3	Web banner	×1		242,000
4	Meeting pass	×2	Incl. admission to the banquet	64,000
5	Screen advertising	×1	All lecture rooms	187,000
Total normal price				2,550,000



Sponsorship Package (2)

Please refer to the respective pages for details on each benefit.

○ Meeting website: <https://neuroscience2025.jnss.org/en/index.html>

○ Application: Please apply via the online application form on the sponsorship page of the meeting website.

* Applications cannot be canceled unless the organizing committee deems the reason to be beyond the applicant's control. Please check the cancellation policy for further details.

○ Contact: Neuroscience 2025 Sponsorship Secretariat (c/o A&E Planning Co.,Ltd.)
Email : e_jns2025@aeplan.co.jp

* Priority within each package level will be assigned on a first-come, first-served basis.

* If you wish to hold the luncheon seminar as a web seminar, please contact the sponsorship secretariat.



The 48th Annual Meeting of the Japan Neuroscience Society

Luncheon Seminar



Luncheon Seminar (1)

Luncheon seminars will be co-hosted with the 48th Annual Meeting of the Japan Neuroscience Society.

- Venue: Lecture rooms
- Date & Time: July 24 - 26, 2025 at lunch time
- Lecture time: 50 minutes
- Language: Japanese or English
- Fee:

Date	Time *Tentative	Capacity *Tentative	Fee (Incl.tax)
July 24	11:55 - 12:45	100 - 500 seats	JPY1,760,000
July 25	11:55 - 12:45	100 - 500 seats	JPY1,760,000
July 26	11:55 - 12:45	100 - 500 seats	JPY1,760,000

3 to 6 seminars per day will be held in parallel. This is subject to change depending on the number of applications. Please note that the date and room for each seminar will be determined by the organizing committee, taking into account the preferences of the applicants.

* The time slot may be adjusted for scheduling reasons.

* If you wish to hold the luncheon seminar as a web seminar only, please contact the sponsorship secretariat. (Web seminar only: JPY1,650,000 (Incl. tax))



Luncheon Seminar (2)

- Application: Please apply via the online application form on the sponsorship page of the meeting website.
 - * Applications cannot be canceled unless the organizing committee deems the reason to be beyond the applicant's control. Please check the cancellation policy for further details.

- Application deadline: Advance reservation available March 14, 2025

- Payment: An invoice will be sent after your application. Please ensure payment is made before the due date specified on the invoice.
 - *Please cover any bank transfer fees.

- Disclosure of information:
 - We agree that the sponsors disclose their contributions.

- Contact: Neuroscience 2025 Sponsorship Secretariat (c/o A & E Planning, Co., Ltd.)
Email : e_jns2025@aeplan.co.jp

- Remarks
 - Lecture room facilities
 - The seminar fee includes standard audio-visual equipment (projector, screen, microphone, etc.) and staff responsible for video, audio, and lighting. Additionally, two meeting passes for participation in the meeting program will be provided. If any additional equipment, such as video and audio recording, is required, separate charges will apply. Please contact the secretariat for details.

 - Program
 - The program will be organized by the executive committee and informed to the seminar co-hosts by the secretariat.

 - What is NOT included in the seminar fee
 - The following costs are NOT included in the seminar fee and will be charged separately by the secretariat after the meeting:

 - Box lunch with packet drink (green tea) for participants
 - Since the seminar will be held during lunchtime, please arrange for lunch. The cost of a box lunch with a packet drink (green tea) is JPY 1,540 per box (tentative).
 - The number of box lunches needed will be determined by the co-host after the application deadline, and the secretariat will then place an order for the total number required.



Luncheon Seminar (3)

- Optional items

- ① Operating staff (announcements, timekeeping, distributing handouts and lunch, guiding, etc.)

- *This will be arranged separately from the operating staff for the meeting.

- ② Honorarium and travel expenses for speakers and chairs

- ③ Signage/Display: Signboards in front of the room etc.

- ④ Additional equipment: Video and audio recording, simultaneous interpretation, anteroom facilities, etc.

- ⑤ Food and drink for anteroom

- ⑥ Operating expenses

- * If you order any of the above optional items, a 10% service fee will be charged in addition to the total amount of optional item fees.

- An advance reservation system for luncheon seminar tickets will be available for participants.

- The information of participants who make a reservation will be provided to each seminar co-host.

- The schedule and procedure will be communicated by the secretariat after the application.

- Acquisition of Personal Information and Use of the System

- Please read the following terms and conditions regarding the acquisition of personal information and the use of the system, and check the box on the application form.

- 1. Resale of acquired personal information is prohibited.

- 2. Acquired personal information shall only be used within the company, unless otherwise agreed by the individual.

- 3. If an individual refuses to provide information or to communicate, the use of his/her personal information shall be discontinued.

- 4. Appropriate precautionary measures must be taken by assigning a personal information manager to prevent the loss or leakage of acquired personal information.

- 5. If any personal information that clearly appears to be erroneous is obtained, it will not be used and will be deleted.

- 6. Other appropriate measures shall be taken in accordance with the Act on the Protection of Personal Information.



The 48th Annual Meeting of the Japan Neuroscience Society

Advertising

Program booklet advertising

Web banner advertising on the meeting website

Screen advertising

Congress bag sponsor

Flyer insertion in congress bags

Neck strap sponsor



Advertising (1)

■ Program booklet advertising

- Advertising medium: The 48th Annual Meeting of the Japan Neuroscience Society Pocket Program
- Book size & Printing method: B5 (257 mm height×182 mm width), approx. 40 pages
Offset printing (Front cover: 4 colors / Body: Black and White), Perfect binding
- Circulation: 3,000 copies
- Distribution recipients: Meeting participants
- Budget: JPY3,000,000
- Rate: *Incl.tax

Page	Size	Color	Rate	No. of slots
Cover 4 (Back cover)	B5 : 1 page	4 colors	JPY297,000	1
Cover 2 (Inside front)	B5 : 1 page	Black and White	JPY187,000	1
Cover 3 (Inside back)	B5 : 1 page	Black and White	JPY154,000	1
Back matter 1 page	B5 : 1 page	Black and White	JPY99,000	Up to 15

Please note that the placement of back matter advertisements will be managed by the organizer.

- Application: Please apply via the online application form on the sponsorship page of the meeting website.
- Application deadline: April 18, 2025
- Ad submission deadline: April 25, 2025
- Ad size: 225 mm height×150 mm width
- Ad requirements: Print-ready data (Please attach a print sample.)
 - Format
 1. Adobe illustrator
Please outline all fonts and embed all images. Also, please specify your operating system and the version of Illustrator used for creating the ad. Proofreading will be performed by the printer. Please note that a proof sheet will not be sent to you.
 2. PDF
Please outline all fonts and embed all images. If MS-Word or MS-PowerPoint is used for creating the ad, please make sure to specify the application used. Please note that submitted data may not be accepted.
- Ad submission: Please send ad data to the sponsorship secretariat via email.
- Payment: An invoice will be sent after publishing. Please ensure payment is made before the due date specified on the invoice.
- Disclosure of information: We agree that the sponsors disclose their contributions.



Advertising (2)

■ Web banner advertising on the meeting website

- Advertising medium: Website of the 48th Annual Meeting of the Japan Neuroscience Society
- Advertising form: Web banner advertising
- URL: <https://neuroscience2025.jnss.org/en/index.html>
- Number of banners: 10 *tentative
- Display method: On the homepage - Ads will be displayed below the key visual (in the middle of the page).
On other pages - Ads will be shown in the footer.
* When multiple ads are placed, they will be displayed randomly.
- Rate: JPY242,000 /banner (Incl.tax)
- Application: Please apply via the online application form on the sponsorship page of the meeting website.
- Placement period: Applications are accepted anytime after the website is launched in July, 2024. Ads are guaranteed to be displayed until one month after the meeting.
- Banner size: Height 80 pixels × Width 228 pixels
- Format: GIF (Animation GIF, Infinite loop are acceptable) /JPEG/PNG etc.
- Banner submission: Please send the banner data to the sponsorship secretariat via email. Also, please include the URL that the banner should link to.
- Payment: A banner will be placed within 7 business days after receipt, and then, an invoice will be sent. Please ensure payment is made before the due date specified on the invoice.
- Disclosure of information: We agree that the sponsors disclose their contributions.
- Contact: Neuroscience 2025 Sponsorship Secretariat (c/o A & E Planning, Co., Ltd.)
Email : e_jns2025@aeplan.co.jp



Advertising (3)

■ Screen advertising

- Advertising medium: Screens at the 48th Annual Meeting of the Japan Neuroscience Society
- Advertising form: Screen advertising
- Details: Promotional slides and videos will be projected onto the screens in the lecture rooms and the rest area during break times.
- Number of slots: 10 *tentative
- Display method: Looping display of up to 20 seconds per slot
- Rate: JPY187,000 /slot (Incl.tax)
- Application deadline: May 30, 2025
- Application: Please apply via the online application form on the sponsorship page of the meeting website.
- Projection period: During the meeting (July 24 – 27, 2025)
- Format: Microsoft PowerPoint (Resolution: XGA / Aspect ratio: 16:9)
- Ad submission: Please send the ad data to the sponsorship secretariat via email.
- Payment: An invoice will be sent before the meeting. Please ensure payment is made before the due date specified on the invoice.
- Disclosure of information: We agree that the sponsors disclose their contributions.
- Contact: Neuroscience 2025 Sponsorship Secretariat (c/o A & E Planning, Co., Ltd.)
Email : e_jns2025@aeplan.co.jp



Advertising (4)

■ Congress bag sponsor

- Advertising medium: Congress bags for the 48th Annual Meeting of the Japan Neuroscience Society
- Advertising form: Congress bag advertising
- Details: Your company's logo will be printed on the congress bags that will be distributed to participants.
- Number of slots: 2
- Rate: JPY385,000 /slot (Incl.tax)
- Application deadline: May 16, 2025
- Application: Please apply via the online application form on the sponsorship page of the meeting website.
- Format: Adobe illustrator, Print-ready data
- Ad submission: Please send the ad data to the sponsorship secretariat via email.
- Payment: An invoice will be sent before the meeting. Please ensure payment is made before the due date specified on the invoice.
- Disclosure of information: We agree that the sponsors disclose their contributions.
- Contact: Neuroscience 20254 Sponsorship Secretariat (c/o A & E Planning, Co., Ltd.)
Email : e_jns2025@aeplan.co.jp



Advertising (5)

■ Flyer insertion in congress bags

- Advertising medium: Flyer insertion in congress bags at the 48th Annual Meeting of the Japan Neuroscience Society
- Advertising form: Flyer
- Details: Flyers will be inserted into the congress bags that will be distributed to participants.
- Number of flyers: 5 *Only 1 flyer per company
- Rate: JPY132,000円 /flyer (Incl.tax)
- Application deadline: May 30, 2025
- Application: Please apply via the online application form on the sponsorship page of the meeting website.
- Size of flyer: A4, 1 page
No rules for printing and colors: both double-sided and single-sided printing, as well as 4-color and black-and-white, are acceptable.
- Flyer submission: Please send 3,000 copies of the flyer to the address designated by the sponsorship secretariat at a later date.
- Payment: An invoice will be sent before the meeting. Please ensure payment is made before the due date specified on the invoice.
- Disclosure of information: We agree that the sponsors disclose their contributions.
- Contact: Neuroscience 2025 Sponsorship Secretariat (c/o A & E Planning, Co., Ltd.)
Email : e_jns2025@aeplan.co.jp



Advertising (6)

■ Neck strap sponsor

- Advertising medium: Neck straps at the 48th Annual Meeting of the Japan Neuroscience Society
- Advertising form: Neck strap advertising
- Details: Your company's logo will be printed on the neck straps that will be worn by participants.
- Number of slot: 1
- Rate: JPY1,870,000円 (Incl.tax)
- Application deadline: May 14, 2025
- Application: Please apply via the online application form on the sponsorship page of the meeting website.
- Format: Adobe illustrator, Print-ready data
- Ad submission: Please send the ad data to the sponsorship secretariat via email.
- Payment: An invoice will be sent before the meeting. Please ensure payment is made before the due date specified on the invoice.
- Disclosure of information: We agree that the sponsors disclose their contributions.
- Contact: Neuroscience 2025 Sponsorship Secretariat (c/o A & E Planning, Co., Ltd.)
Email : e_jns2025@aeplan.co.jp



The 48th Annual Meeting of the Japan Neuroscience Society

**Video Streaming
&
Product Introduction**

■ Video streaming

- Details: Your company-owned videos can be distributed on-demand via the online conference system "Confit", where the participants can view the timetable, abstracts and more. Additionally, your product introduction can be posted with text, image and link.
*The link to YouTube will be embedded.
- Streaming period: July 20 – August 31, 2025 *tentative
- Applicable products & services: Same as the exhibition. Please see the Exhibition section for details.
- Fee: JPY385,000 /slot (Incl.tax)
- Application deadline: May 30, 2025
- Application: Please apply via the online application form on the sponsorship page of the meeting website.
- Payment: An invoice will be sent before the meeting. Please ensure payment is made before the due date specified on the invoice.
- Disclosure of information: We agree that the sponsors disclose their contributions.
- Contact: Neuroscience 2025 Sponsorship Secretariat (c/o A & E Planning, Co., Ltd.)
Email : e_jns2025@aeplan.co.jp
- Image





The 48th Annual Meeting of the Japan Neuroscience Society

Exhibition



Exhibition (1)

■ Exhibition

- Schedule:
- | | |
|---------------|----------------------------------|
| July 23, 2025 | 14:00 - 17:00 (Move-in) |
| July 24, 2025 | 9:00 - 17:00 |
| July 25, 2025 | 9:00 - 17:00 |
| July 26, 2025 | 9:00 - 17:00 (Move-out 17:00 -) |
- *The above schedule is subject to change. Please be sure to check the exhibitor's manual which will be sent at least 1 month prior to the meeting.
- Venue: Exhibition Hall, TOKI MESSE
- Applicable products & services:
- Medical and life science research-related instruments, reagents, disposables, computer systems including software and databases, contract services, introduction and recruitment for universities and research institutions, other research-related services, books, and translation services.
- Applications from companies that do not offer the above products or services will not be accepted.
- Number of booths: 100
- Application deadline: April 25, 2025
- Application:
- Please apply via the online application form on the sponsorship page of the meeting website.
- (1) A confirmation email will be sent after you submit your application.
(2) Following this, another email confirming the receipt of your application will be sent by the sponsorship secretariat.
- Your application will be complete by receiving (1) and (2) mentioned above. Please note that applicants who are not eligible will be notified after a review. If you encounter any issues with the online application, please contact the sponsorship secretariat.
- Payment:
- An invoice will be sent before the meeting. Please ensure payment is made before the due date specified on the invoice.
- * Please inform us if payment cannot be made by the due date on the invoice due to unforeseen circumstances. Otherwise, your application will be canceled, and a cancellation charge will be incurred. Please refer to the cancellation policy page for details.
- Disclosure of information:
- We agree that the sponsors disclose their contributions.
- Contact:
- Neuroscience 2025 Sponsorship Secretariat (c/o A & E Planning, Co., Ltd.)
Email : e_jns2025@aeplan.co.jp



Exhibition (2)

- Booth assignment: After the application period closes, booths will be assigned based on the type, shape, and weight of the exhibits, as well as the number of booths applied for. Exhibitors will be notified of their booth location in the exhibitor's manual.
Please note that no briefing session for exhibitors will be held.

* If you wish to have booths set up side-by-side with your affiliated or associated companies, please inform the sponsorship secretariat by the application deadline.
- Use of display table: Each booth is equipped with a display table. Please indicate the number of booths that do not require a display table on the application form.
- Exhibit management: Please note that exhibitors are responsible for managing their own exhibits. The secretariat will not be liable for any damages caused by theft, loss, fire, or unavoidable accidents during the exhibition.
- Others: Distribution of flyers, catalogs, sample products, or other materials outside of the area in front of your own booth (both inside and outside the buildings where the exhibition and lectures take place) is prohibited. As many exhibitors are expected to participate, your cooperation is greatly appreciated. However, exceptions may be made in cases approved by the Executive Committee.
- Use of exhibition fee: A portion of the exhibition fee will be used to organize a "Stamp Rally" (including prizes, etc.) at the exhibition hall. We welcome sponsorship for the prizes as well. If you are interested, please contact the secretariat.

Exhibition (3)

○ Booth type and Fee

◆ Type A: JPY297,000 /booth (Incl.tax)

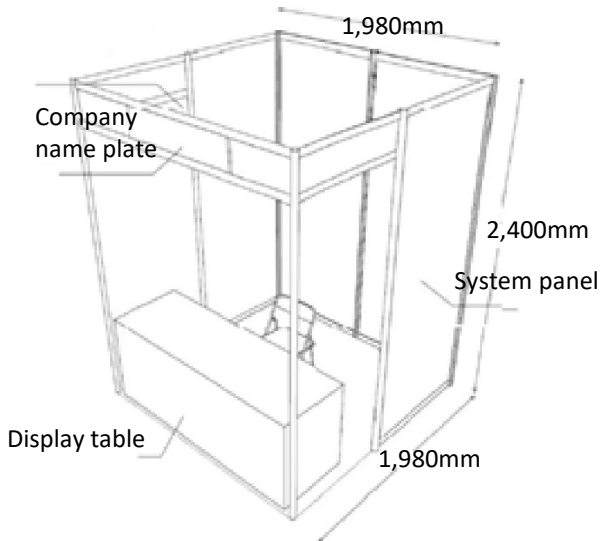

○ Applicable products & services:

Medical and life science research-related instruments, reagents, disposables, computer systems (including software and databases), and contract services.

○ Booth size: W1,980×D1,980×H2,400 (mm)

○ Furniture:

Display table covered with a white cloth (W1,800×D900×H approx.720(mm)), Company name plate, Lighting (FL40W), 1 chair (The no. of chairs depends on the no. of booths applied for.)

○ System panels are used for booths.

Pushpins and nails are not available on the panels to attach panel or poster.

○ 4 exhibition staff badges per booth will be provided.

○ **1 meeting pass to participate in the meeting program will be provided.**

◆ Type B: JPY33,000 /booth (Incl.tax)

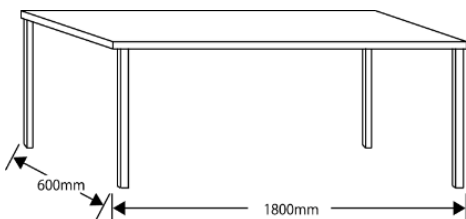

○ Applicable products & services:

Related books, translation services, etc.

○ Booth size: W1,800×D600 (mm) with a white cloth

○ Furniture:

Display table (W1,800×D600 (mm)), 1 chair, Company name plate

○ 4 exhibition staff badges per booth will be provided.

Exhibition (4)

◆ Type C: JPY132,000 /booth (Incl.tax)

* The specifications of the booth will be the same as those for Type A, but the eligible applicants are different.

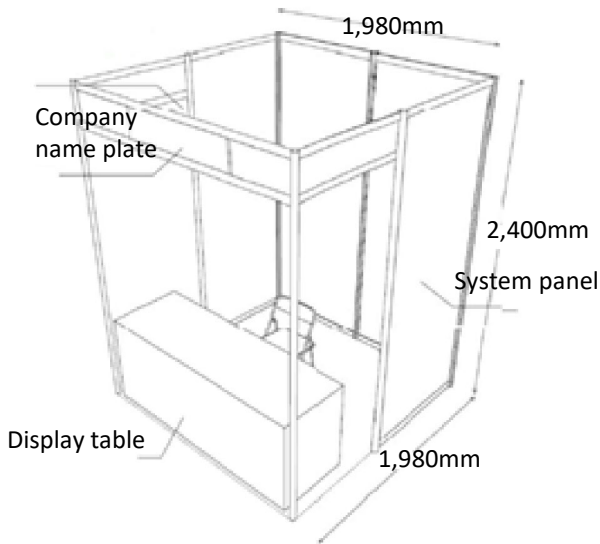

○ Eligible applicants:

Academic institutions such as universities, public institutions, etc.

○ Booth size: W1,980×D1,980×H2,400 (mm)

○ Furniture:

Display table covered with a white cloth (W1,800×D900×H approx.720(mm)), Company name plate, Lighting (FL40W), 1 chair (The no. of chairs depends on the no. of booths applied for.)

○ System panels are used for booths.

Pushpins and nails are not available on the panels to attach panel or poster.

○ 4 exhibition staff badges per booth will be provided.

○ **1 meeting pass to participate in the meeting program will be provided.**

Application is required for the use of electricity (100V).

The exhibitor is responsible for paying both the electricity bill and the costs for electrical installation.

Electricity charges

Up to 500W	JPY33,000 (Incl.tax)
501W - 1KW	JPY38,500 (Incl.tax)

One 2-outlet power strip will be installed per 1KW. Extra outlets and earth terminals incur additional charges.

*For the use of over 1KW, an additional JPY16,500 (Incl. tax) per 1KW will be charged.

*200V power supply (single-phase or three-phase) requires additional installation work and can be quite costly.

At a later date, applications for electricity will be accepted when the "Exhibitor Manual" is sent out.